

ASSEMBLY INSTRUCTIONS

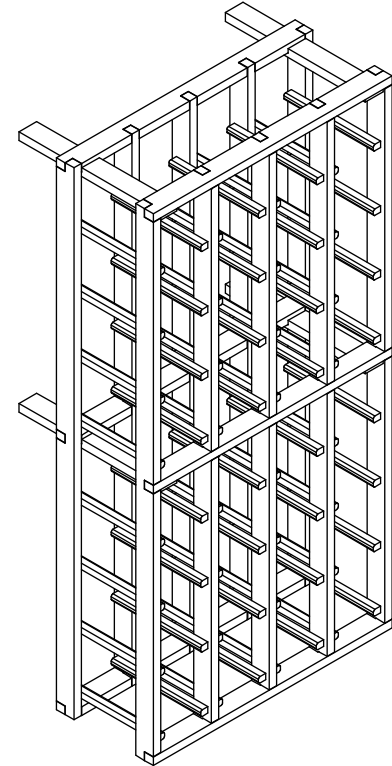

FOR KIT RACKS#

IB 16 32

IB 16 48

IB 32 32

IB 32 48

IB ICE 32

IB ICE 48

INTRODUCTION

Thank you for purchasing a **KIT RACK by Genuwine**. The following instructions will help you assemble kit number IB 16 32. The same procedure can be followed to assemble kits IB 16 48, IB 32 32, IB 32 48, IB ICE 32 and IB ICE 48 .

Please study carefully the instructions prior to starting the assembly.

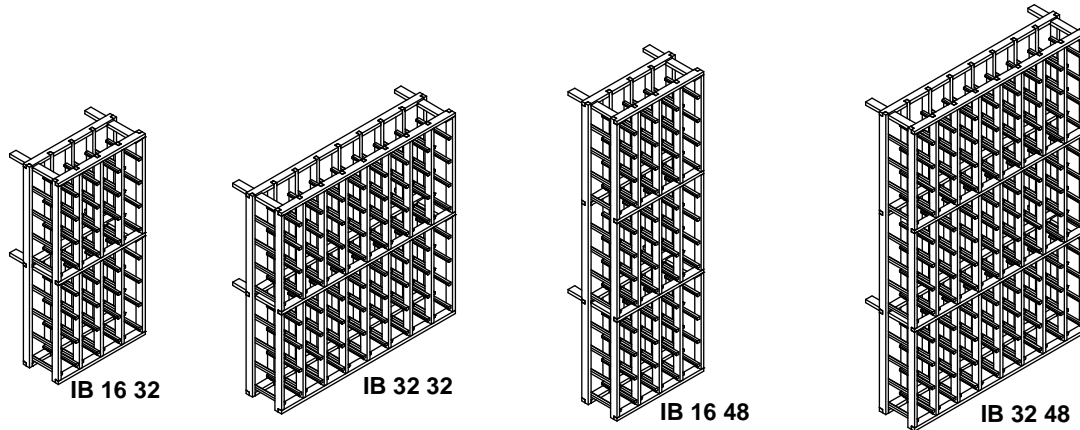

QUANTITY OF COMPONENTS PER KIT

KIT NUMBER	COMPONENT			
	MID LADDER	SIDE LADDER	SPACER BAR	CLEAT
IB 12 32	3	2	6	4
IB 16 48	7	2	6	4
IB 32 32	3	2	8	4
IB 32 48	7	2	8	4
IB ICE 32	4	2	6	4
IB ICE 48	4	2	8	4

COMPONENTS

The following components are included in all kits:

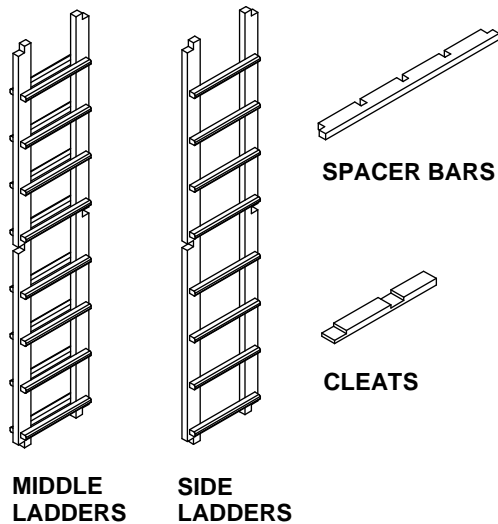

HARDWARE

The following hardware and quantity is included in all kits:



TOOLS NEEDED

The following tools are recommended (NOT INCLUDED):

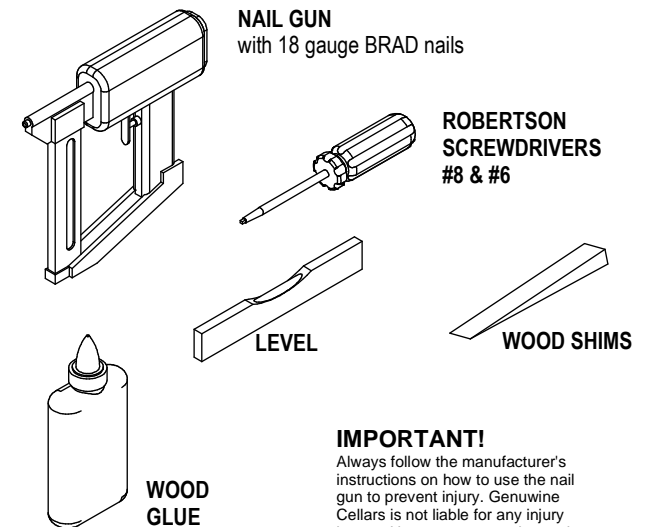

IMPORTANT!
Always follow the manufacturer's instructions on how to use the nail gun to prevent injury. Genuwine Cellars is not liable for any injury incurred by any power tool or tool used to assemble the kit.

ASSEMBLY

STEP 1

APPLY GLUE TO SPACER BAR NOTCHES

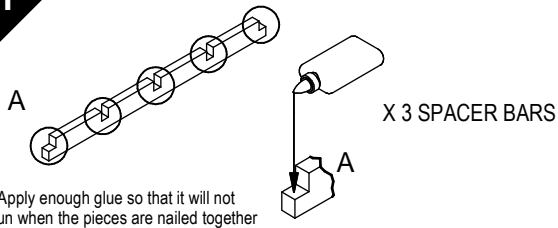

STEP 2

LAYOUT SPACER BARS WITH NOTCHES FACING UP

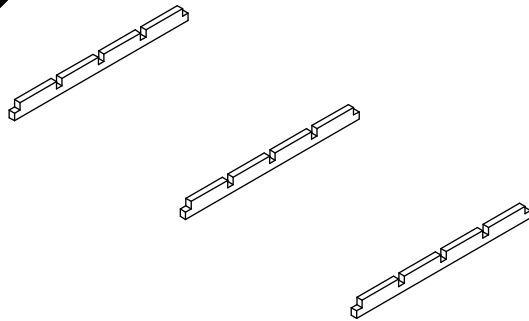

STEP 3

INSERT SIDE AND MIDDLE LADDERS INTO NOTCHES

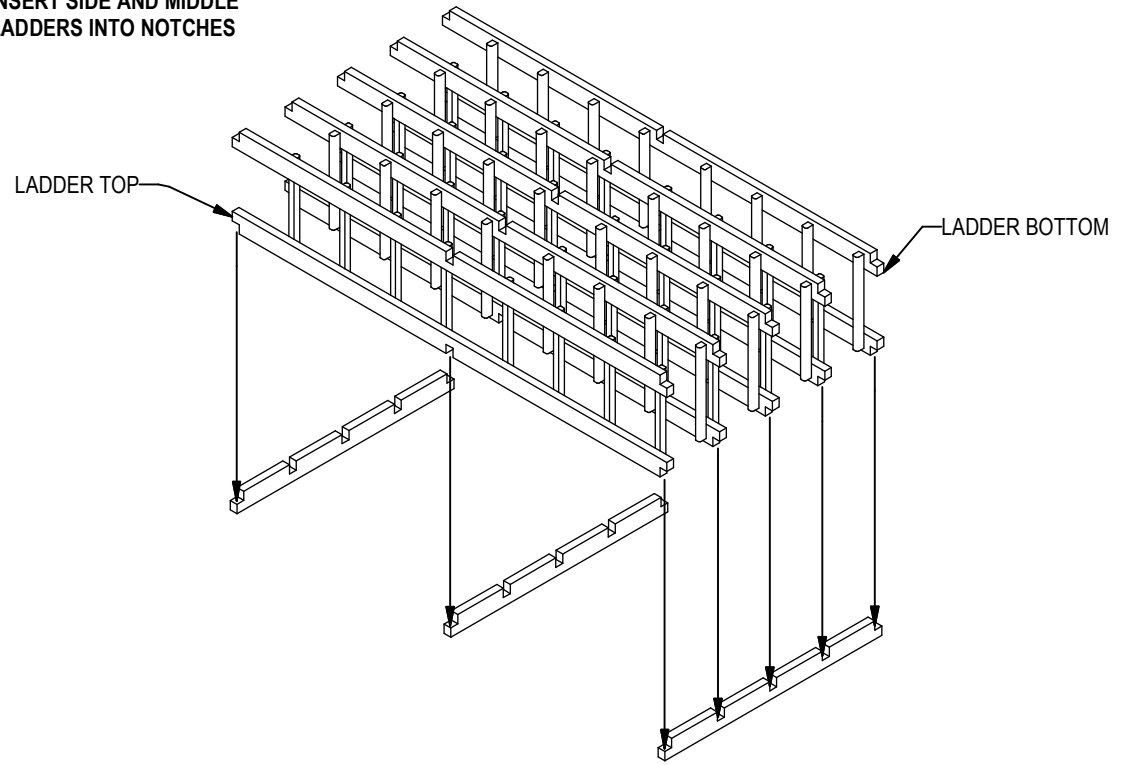

STEP 4

APPLY GLUE TO ALL LADDER NOTCHES AS IN STEP 1

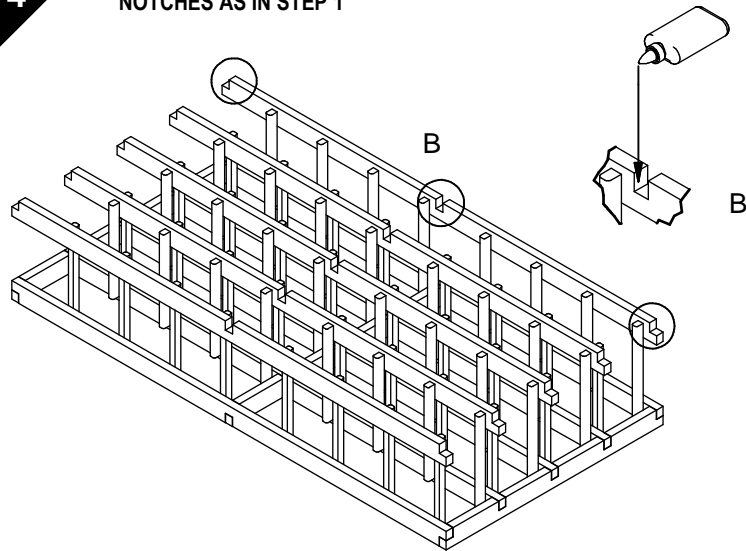

STEP 5

POSITION 3 SPACER BARS INTO LADDER NOTCHES

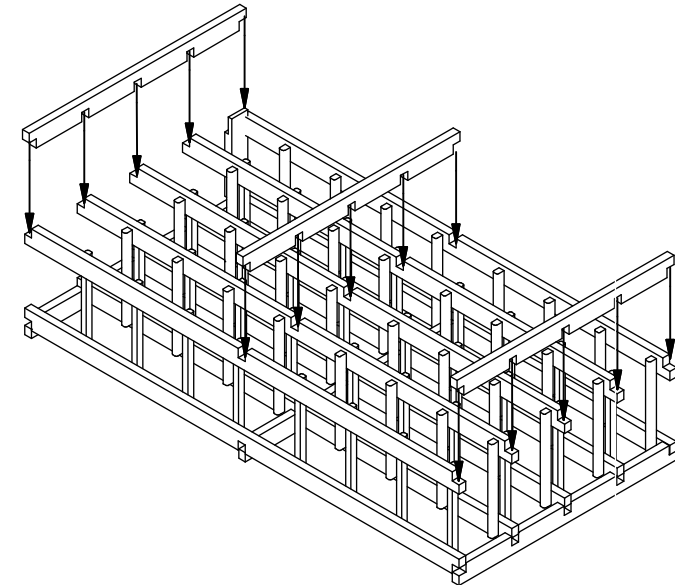

STEP 6

NAIL SPACER BARS TO LADDERS

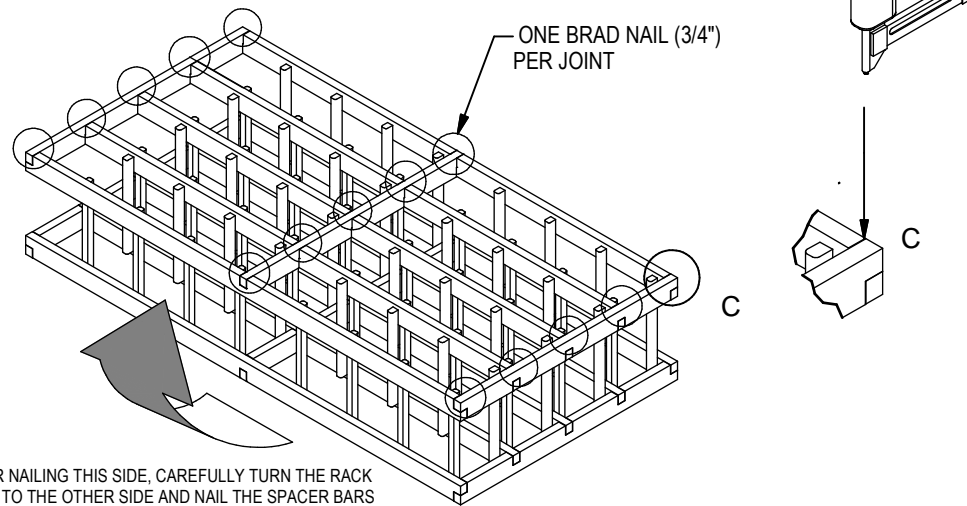

AFTER NAILING THIS SIDE, CAREFULLY TURN THE RACK OVER TO THE OTHER SIDE AND NAIL THE SPACER BARS TO THE LADDERS IN THE SAME WAY AS THIS SIDE.

STEP 7

APPLY GLUE TO CLEAT NOTCHES

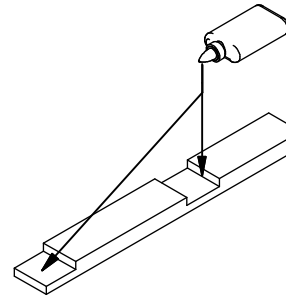

SUGGESTION:
APPLY GLUE & INSTALL THE CLEAT TO THE RACKING

CLEATS POSITIONS FOR EACH TYPE OF RACKING

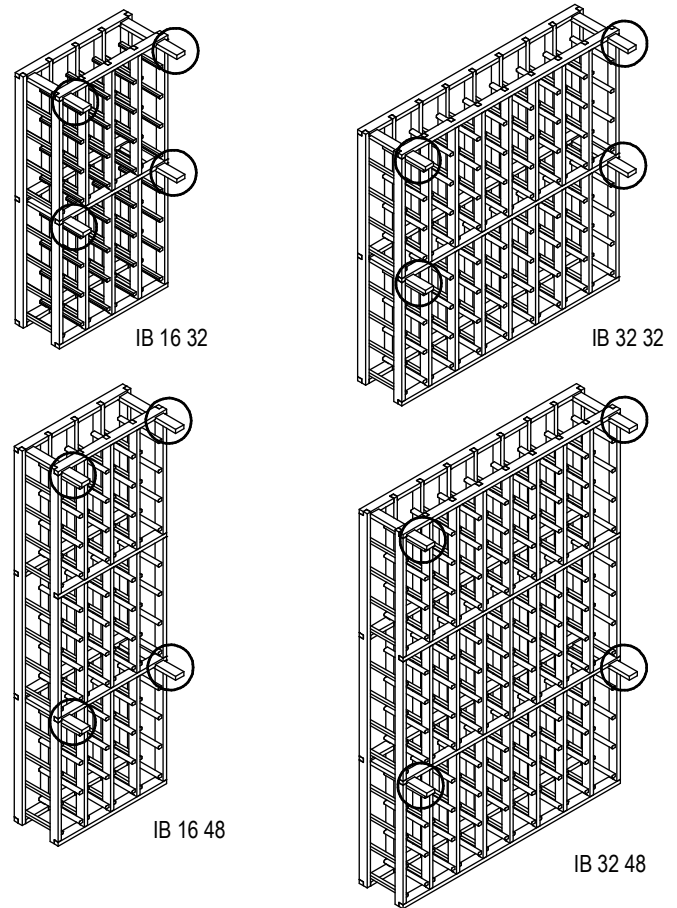

STEP 8

SCREW CLEAT TO RACK

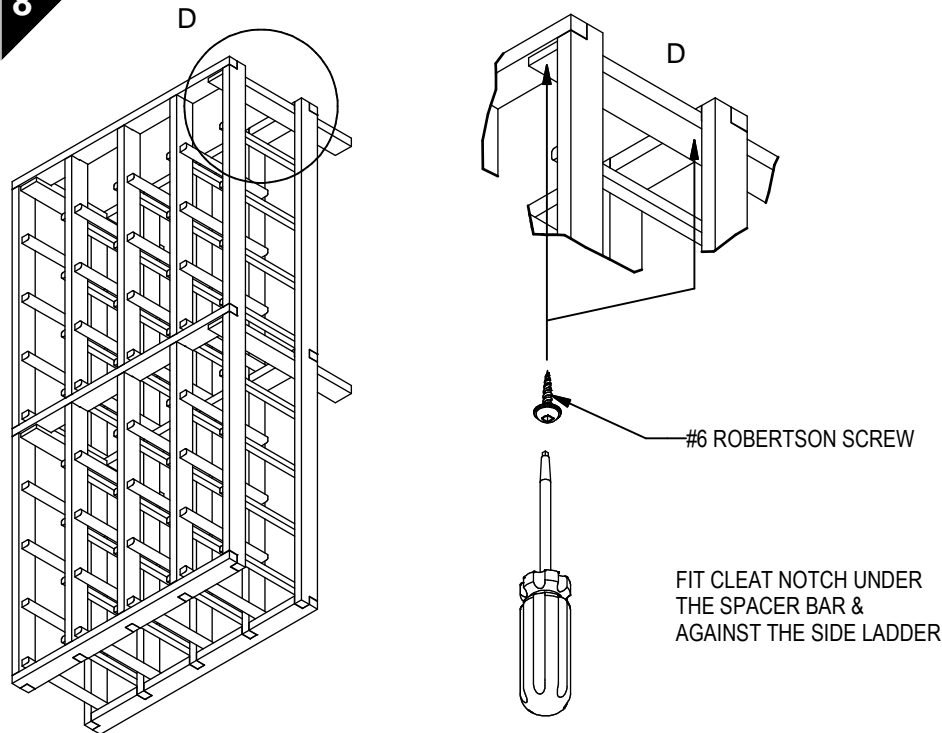

STEP 9

SCREW ANGLED BRACKETS TO EACH CLEAT

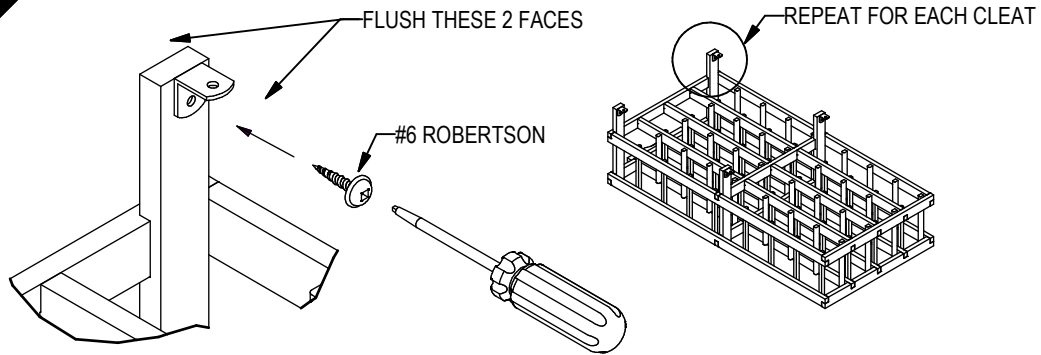

STEP 10

ATTACHING COMPLETED RACK TO BASE (IF RACK IS SITUATED ON FLOOR)

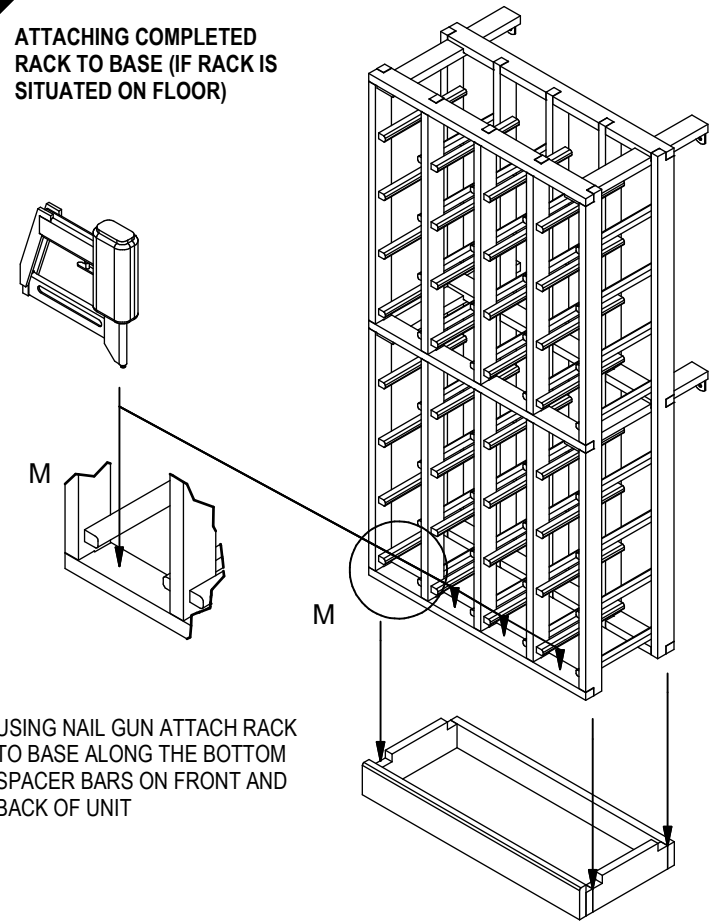

USING NAIL GUN ATTACH RACK TO BASE ALONG THE BOTTOM SPACER BARS ON FRONT AND BACK OF UNIT

STEP 11

ATTACHING COMPLETED UNIT TO WALL AND ADJOINING UNITS

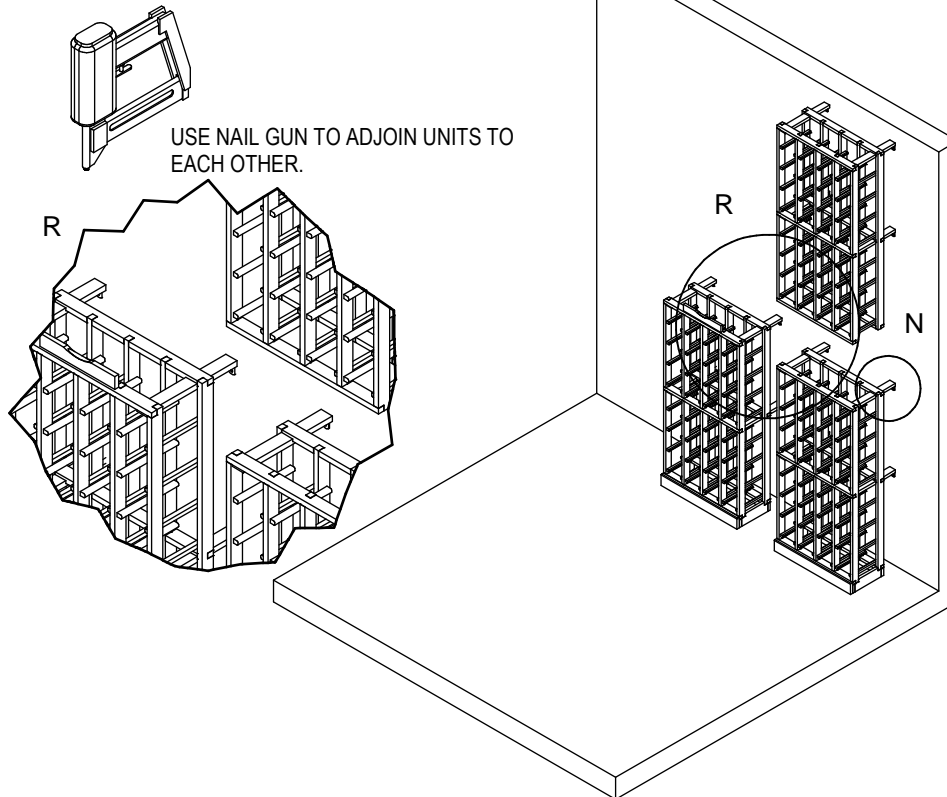

ONCE DESIRED IN POSITION USE #8 PHILLIPS SCREWS TO SECURE THE UNIT TO WALL

